

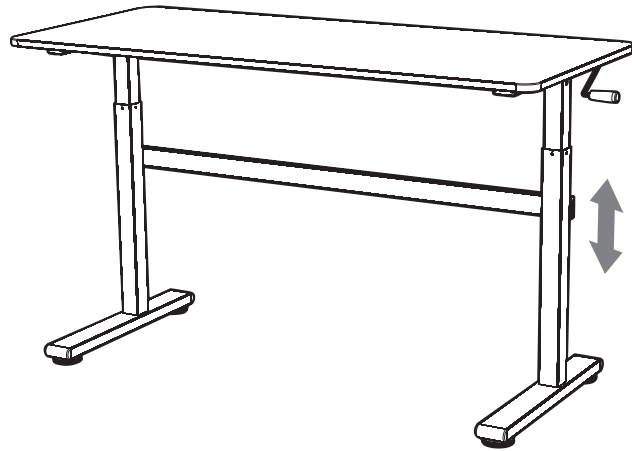

MANUAL SIT-STAND DESK

Instruction Manual

MD-220



Instructions of Safety and Warnings:

- Any failure to comply with the safety and installation instructions in this manual may cause serious bodily injury.
- Any incomplete observation of the instructions, warnings and additional information marked with the "Note" and "⚠" may result in serious damage to the system or its components.
- This product can be used by children aged from 8 years and above if they have been given supervision or instruction concerning use of the appliance in a safe way and understand the hazards involved. Children shall not play with the appliance. Cleaning and user maintenance shall not be made by children without supervision.
- Persons with reduced physical, mental abilities and or lack of experience and knowledge must not use the product, unless they're under supervision, understand the hazards involved or they have been thoroughly instructed in the use of the apparatus by a person who is responsible for the safety of these persons.
- Users should make sure that they never sit on the desktop in order to prevent serious bodily injury.



Other Safety Instructions:

- Clear up all obstacles within the height adjustment range.
- Any attempts to reconstruct the desk frame aren't allowed.
- Don't add anything to the adjustable junctions of the desk frame.
- Outdoor use is prohibited.



Disposal: The product with this mark indicates that this product shouldn't be disposed with other household wastes throughout the EU. To prevent possible harm to the environment or human health from uncontrolled waste disposal, recycle it responsibly to promote the sustainable reuse of material resources. To return your used device, please use the local recycle service or contact your point of purchase to withdrawn the product.

Checklist and Installation

Please check all of the components shown in the component checklist. If any of the components are missing or damaged, contact your point of purchase for a replacement.



What tools are needed to assemble the desk frame?



What important specifications should know before installation?



1. Inserting the Sync Rod

- Place two **Lifting Columns (A)** as shown. Insert left end of the **Sync Rod (B)** into the left column. Attach the right column to the right end of the sync rod. Precisely adjust the hole on the right column to align with the sync rod using a **Crank Handle (F)**.

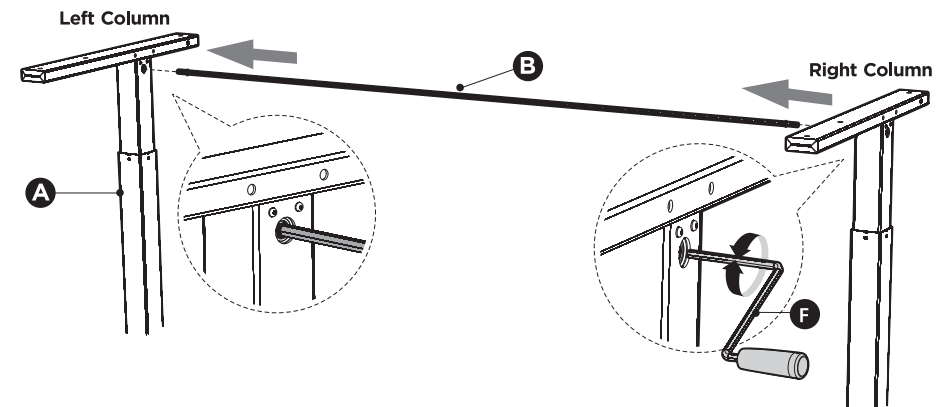

2. Assembling the Crossbar

- Attach the **Crossbar C** to the top of the columns using **4 Screws S-C**.
- Attach the **Crossbar D** to the middle of the columns using **4 Screws S-A**.

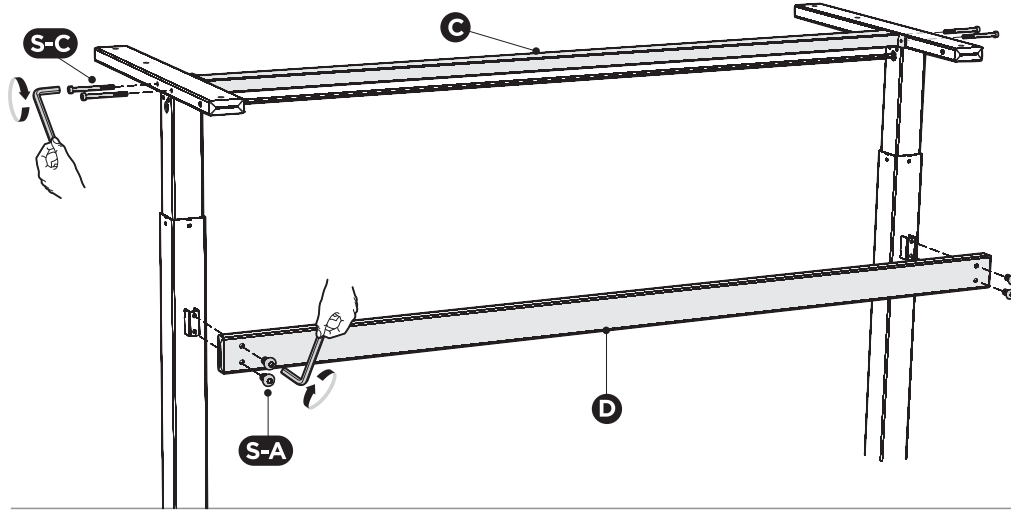

3. Apply the Silicone Pads as Shown

- Position the **Silicone Pads S-D** as close to the frame holes as possible.

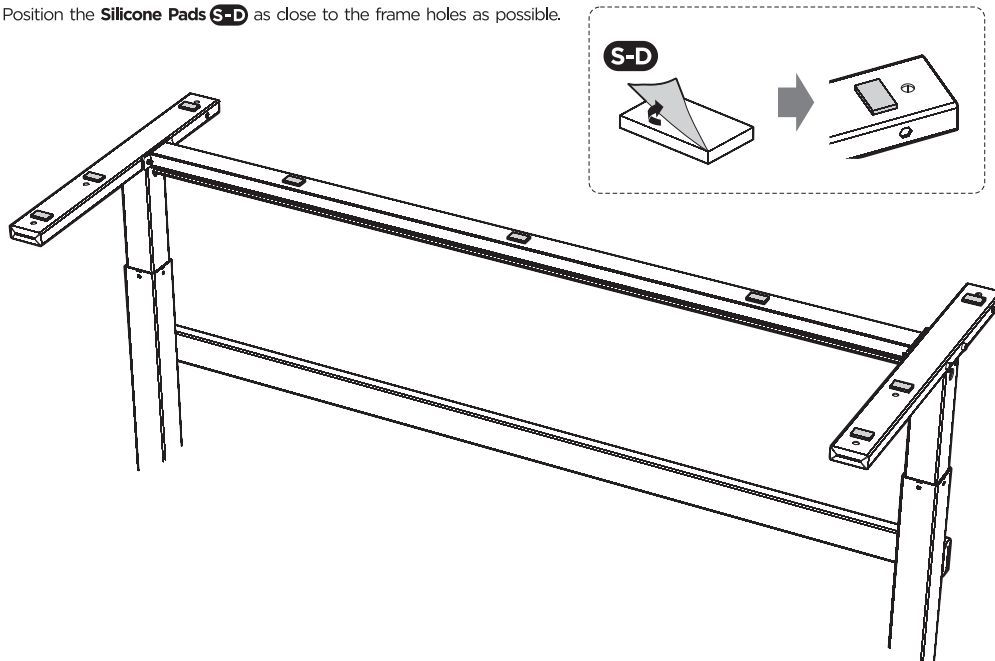

4. Attaching the Desktop

- With assistance from another person, carefully place the assembled desk frame upside down onto the desktop.
- Position the frame in the center of the desktop leaving no more than 85mm of edge space on all sides.
- Mark and drill screw holes into the desktop. (Note: do not drill all the way through desktop material.)
- Insert and tighten **screws S-B**. Use washers **S-B**.

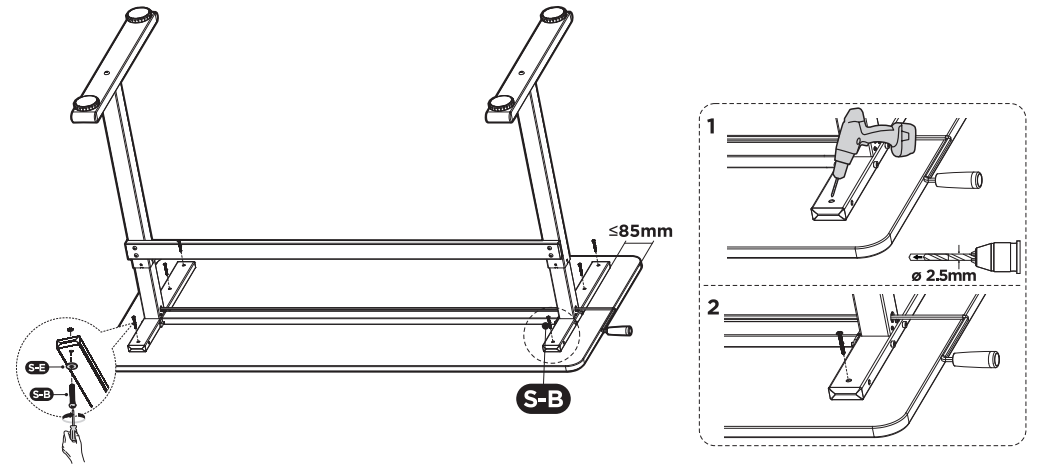

5. Attaching the Crank Handle and Adjusting the Desk

- Insert the crank handle into the hole found on both columns as shown in **Figure 1** and adjust the desk to the desired height.
- Once you have adjusted to desk to the desired height, remove the crank handle and insert it into the storage hole found on the top frame member as shown in **Figure 2**.
- To adjust and level the desk, use the adjustable feet found on the bottom of each foot as shown in **Figure 3**.
- Check for proper horizontal placement by using a bubble level (not included) as shown in **Figure 4**.

